



MPK10

BATTERY POWERED



REMOTE CONTROL



- ✓ Proportional & Precise
- ✓ Intuitive layout
- ✓ Spare battery on board

+ WIRE CONTROL

- ✓ Intuitive wire control

REMOTE CONTROL FORWARD & REVERSE FUNCTIONS



2183 lb HOOK



SPECIAL FEATURES

- ✓ 2182 lb runner Jib
- ✓ USB port for phone charging
- ✓ Big tool box
- ✓ Vacuum pump on board
- ✓ Removable counterweight

360° MANIPULATOR ROTATION

MAIN BOOM

- ✓ 2183 lb MAX capacity
- ✓ 2 hydraulic extensions
- ✓ High-resistance steel



2183 lb GLASS MANIPULATOR



1323 lb GLASS MANIPULATOR



± 9° ROTATION

SIDE STABILIZERS



LONG-LASTING BATTERY



- ✓ 220V charger
- ✓ 110 V charger 

WHEELS



- ✓ Twin wheels available
- ✓ White non-marking tires available

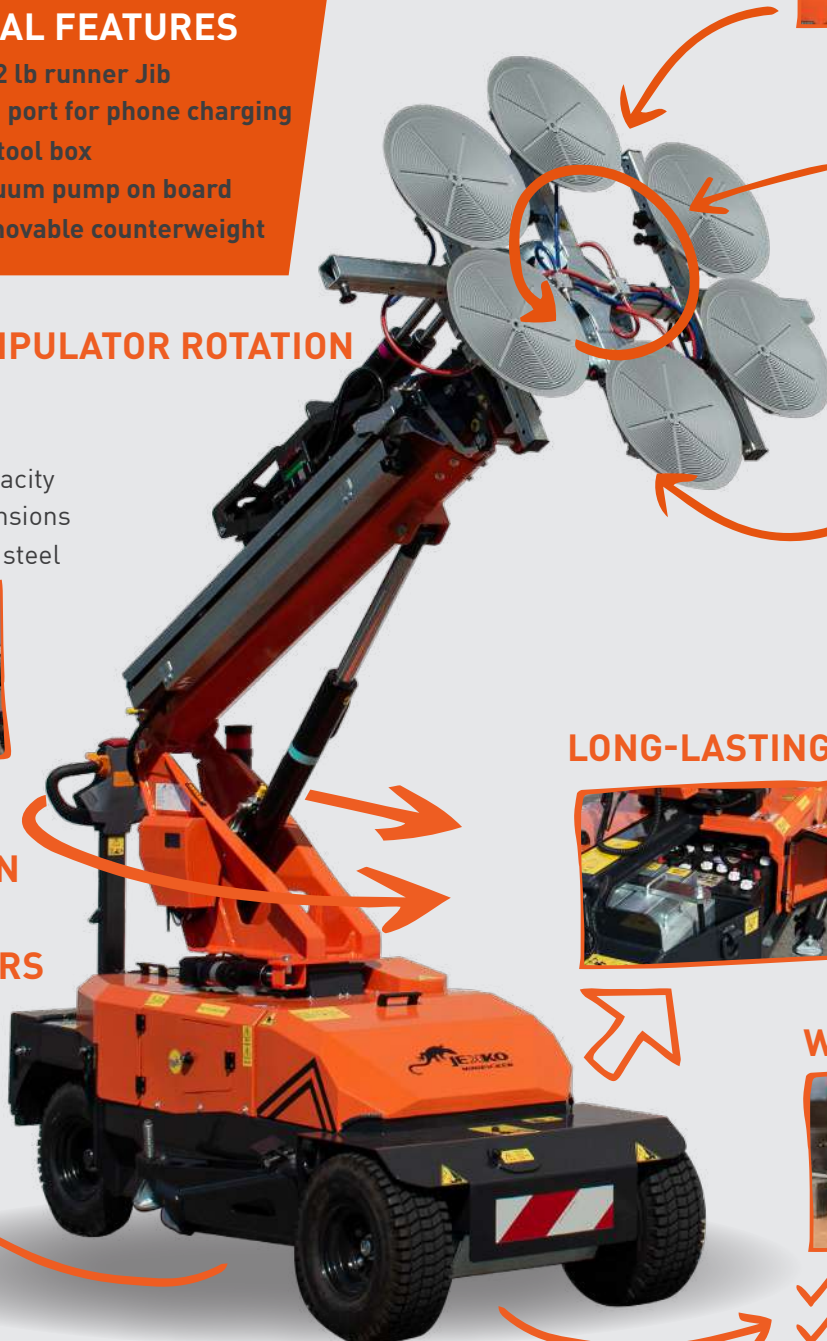



DIMENSIONS



	lb
MPK10	2304
Counterweight	507
JVM10	364



LOAD CHART WITH 2183 lb MANIPULATOR

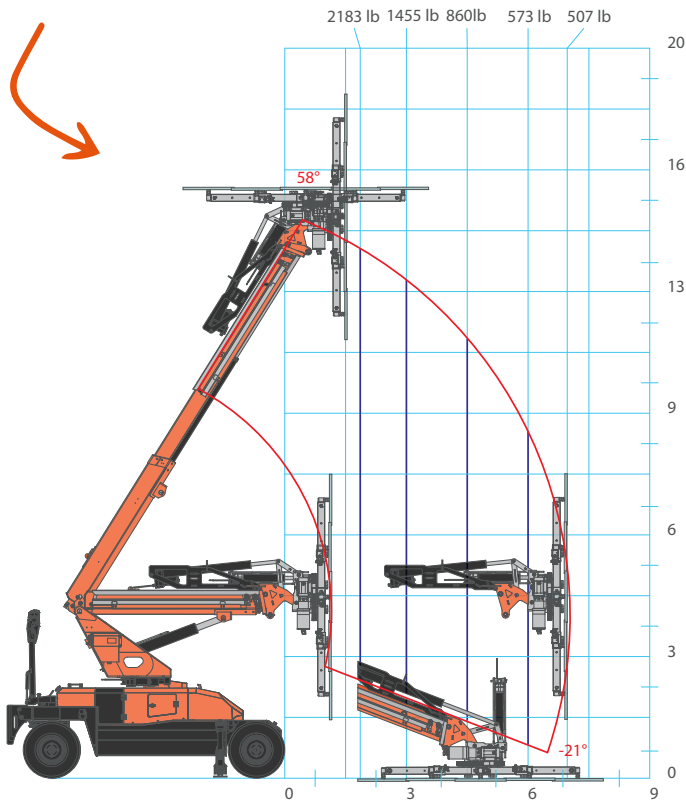

LOAD CHART WITH RUNNER JIB

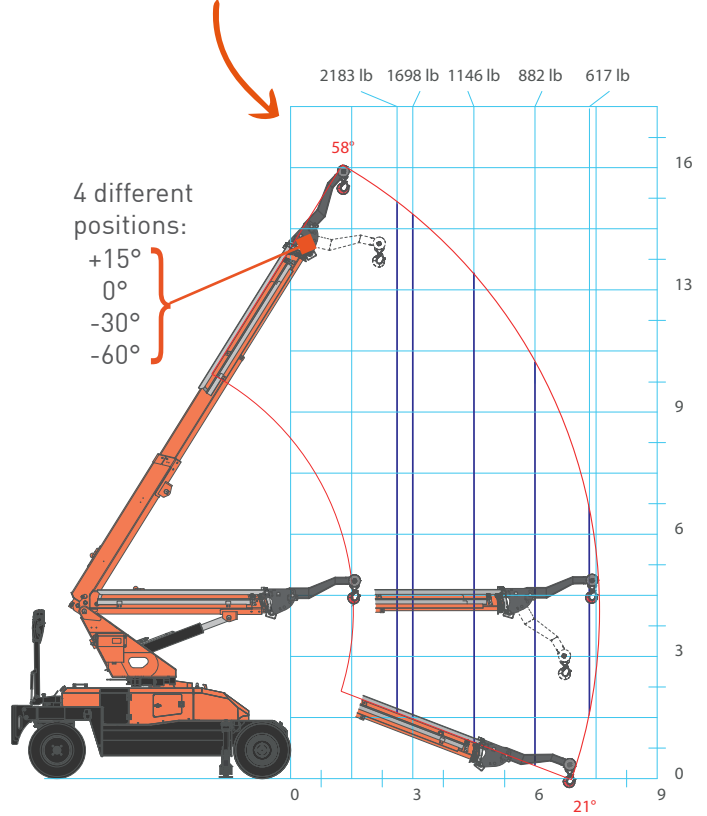

ACCESSORIES

JVM10EV
2183 lb glass manipulator

JVM06EV
1323 lb glass manipulator

2183 lb RUNNER JIB

